

**stella**<sup>™</sup>  
**System**

**USER GUIDE**

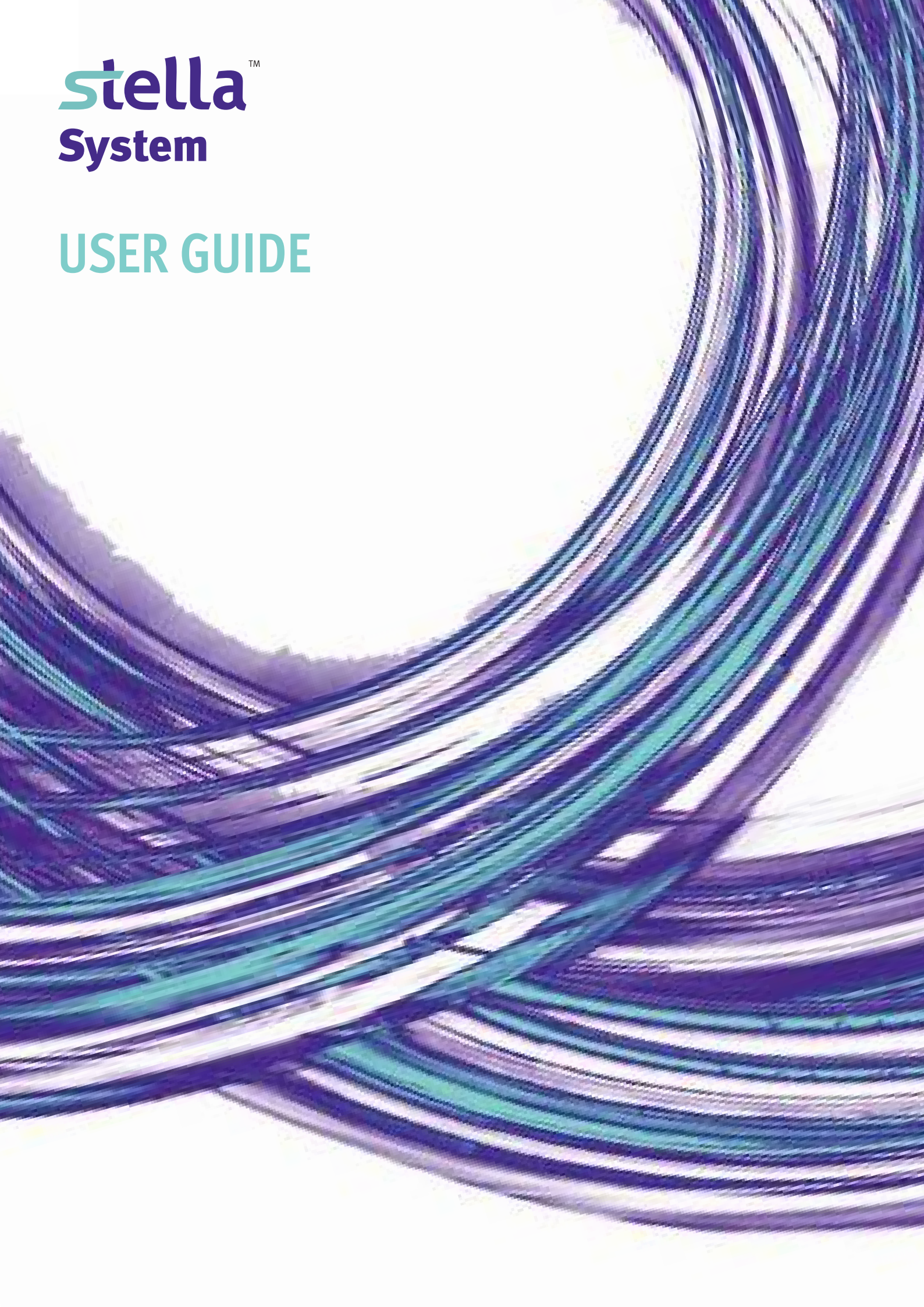

# CONTENTS

	PAGE NO.
<b>SECTION 1 INTENDED USE</b>	<b>1</b>
<b>SECTION 2 COMPONENTRY</b>	<b>3-7</b>
<b>SECTION 3 GETTING STARTED</b>	<b>9-10</b>
<b>SECTION 4 HOW TO USE</b>	<b>12-18</b>
Stella System A	12-13
Stella System B	14-15
Stella System C	16-18
<b>SECTION 5 MAINTENANCE</b>	<b>20-25</b>
Battery Management	20
Lubing IQ Process	20
Bluetooth Pairing Process	21
Barcode Validation	21-22
Downloading	22-23
Replacing the Pump Hose and Tube Set	24-25
Cleaning and Disinfecting Stella	25
<b>SECTION 6 TROUBLESHOOTING AND FREQUENTLY ASKED QUESTIONS</b>	<b>27-30</b>
<b>SECTION 7 WARRANTY</b>	<b>32</b>
<b>SECTION 8 COMPLIANCE</b>	<b>34-42</b>
<b>SECTION 9 STELLA AGENTS</b>	<b>44-45</b>

*The Operating Instructions in this manual outline general safety guidelines for the correct operation of Stella System, applicable to all variants.*



*Carefully read and understand the user instructions before operating Stella, IQ, or Pulse.*



*The Stella System can only be used in combination with Tristel Fuse for Stella for semi-automated disinfection.*



*The Stella System can only be used in combination with Tristel Clean for Stella for semi-automated cleaning.*



*Never use Stella, IQ, Pulse, or Cradle for any purpose other than the Intended Purpose.*



*Do not use Stella for the reprocessing of surgical equipment or medical devices intended for autoclaving.*



*Refer to the Safety Data Sheet of the approved disinfectant and cleaning agent prior to use.*



*Should IQ or Pulse appear to malfunction, download the data and follow the graphic messages on the IQ display. This will allow you to take appropriate corrective action or to arrange for repair.*



*All repairs must be carried out by an approved and qualified Stella service technician.*



*Do not use Stella IQ, Pulse, or Cradle, including IQ or Pulse power adaptors, if they have been damaged or have changed in performance.*



*Ensure that the device to be reprocessed is compatible with the Stella System prior to use.*



*For professional use only.*

# SECTION ONE

## INTENDED USE

## SECTION 1, INTENDED USE

The Stella System is a semi-automated washer disinfecter designed specifically for the disinfection of invasive and non-invasive, heat-sensitive, non-lumened, and single-lumened medical devices.

### PRODUCT VARIANTS



#### stella™ System A

**Indication for Use:** For the high-level disinfection of non-lumened medical devices, such as nasendoscopes, transoesophageal echocardiography probes, transvaginal probes, transrectal probes, manometry catheters, and laryngoscope blades.



#### stella™ System B

**Indication for Use:** For the high-level disinfection of non-lumened (see above) and single-lumened medical devices, such as hysteroscopes, cystoscopes, intubation endoscopes, and bronchoscopes.



#### stella™ System C

**Indication for Use:** For the cleaning and high-level disinfection of single-lumened and non-lumened medical devices, such as those listed above.

# SECTION TWO

## COMPONENTRY

# SECTION 2, COMPONENTRY

## STELLA BASE

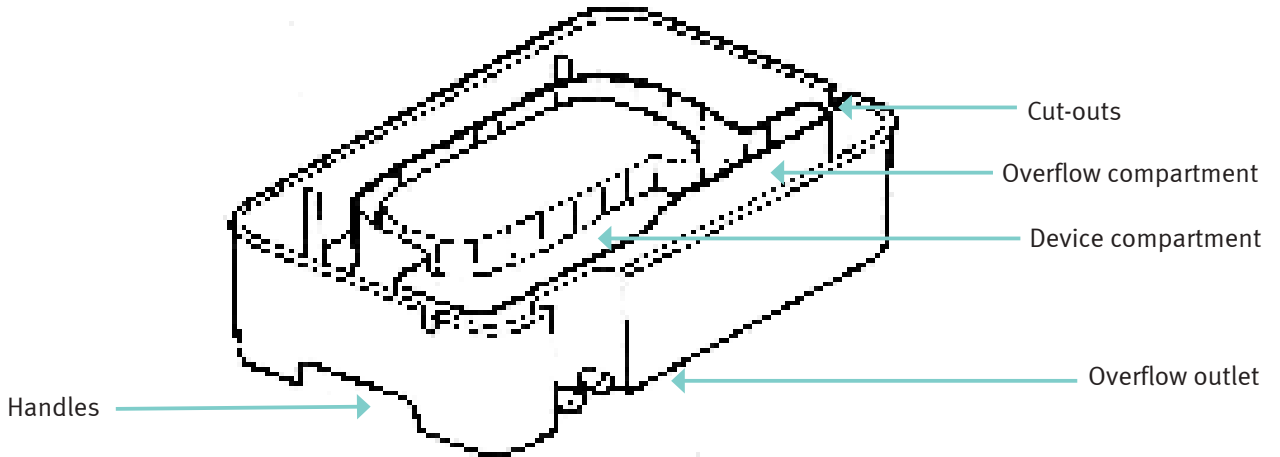

## STELLA LID

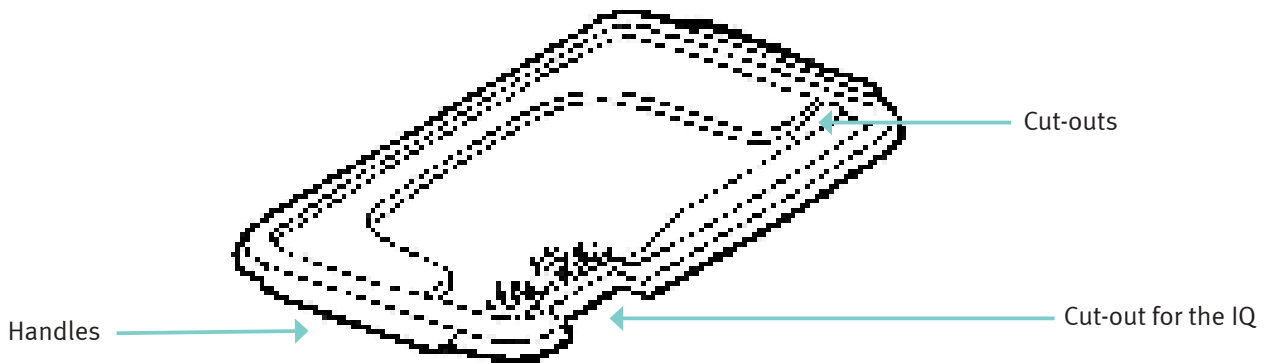

## ACCESSORIES



The Small Parts Tray and Lid for securing device accessories in the Stella Base.



The Drainage Outlet Cap for covering outlets of the Base during transportation. The Cap should not be used on a full tray of disinfectant. It is for containing disinfectant residues only.



The Stella Jug for preparation of Tristel Fuse for Stella and Tristel Clean for Stella working solutions.



The grommets for closing the cut-outs when they are not being used.



The Drainage Hose for draining out any excess liquid, after the completed contact time.



The Stella Lube, a lubricant needed for set up and maintenance of the IQ.

## STELLA IQ

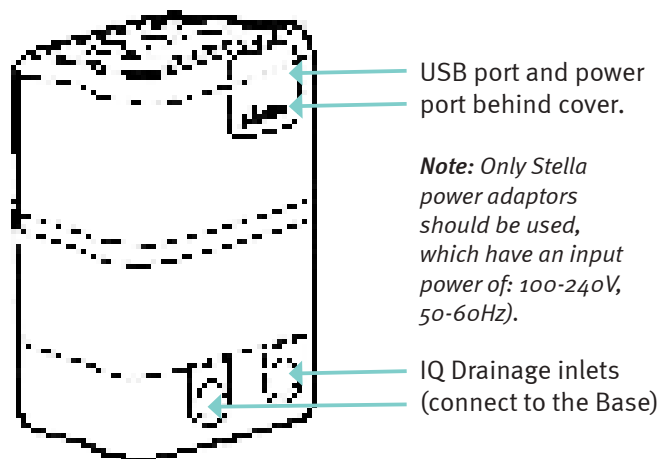
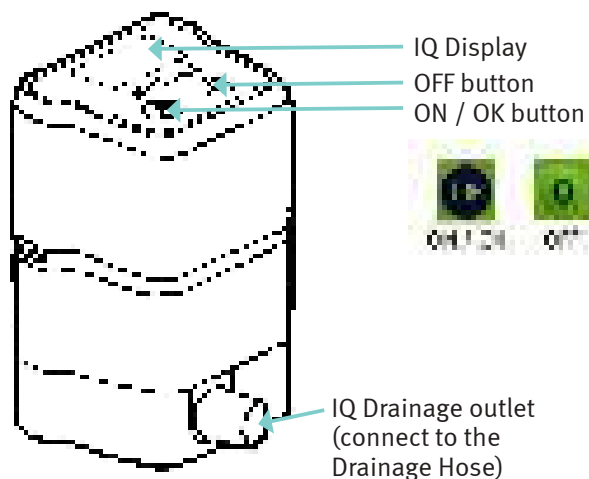

## STELLA PULSE

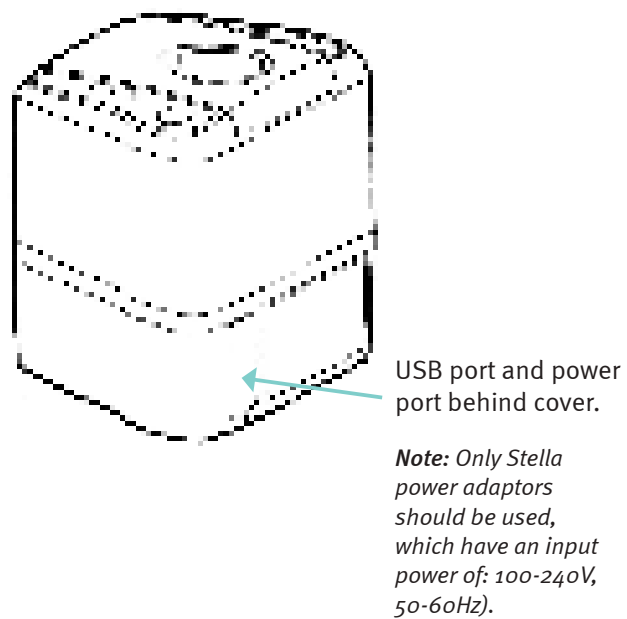
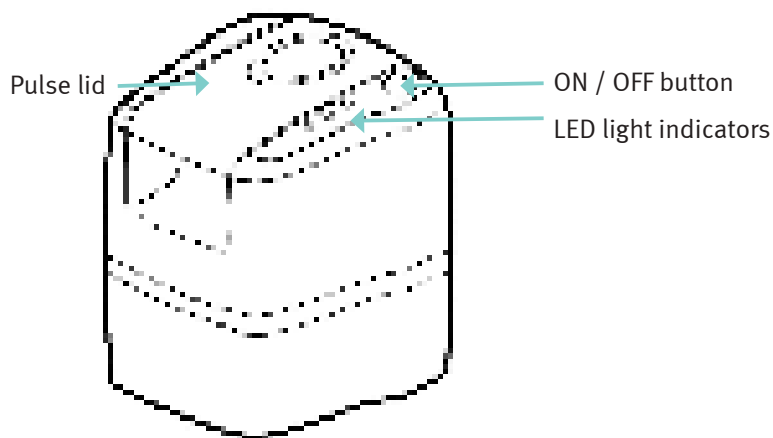

## PULSE TUBE SET

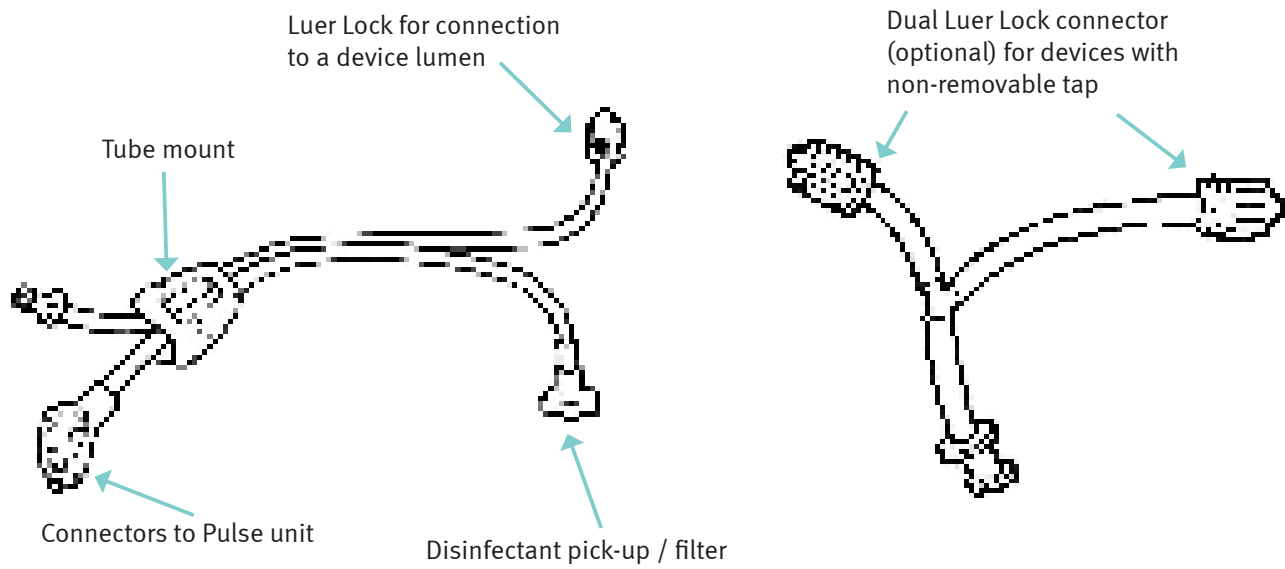

## STELLA CRADLE

### STELLA A

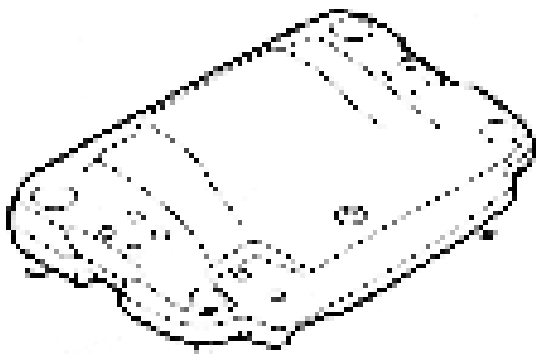

### STELLA B AND C

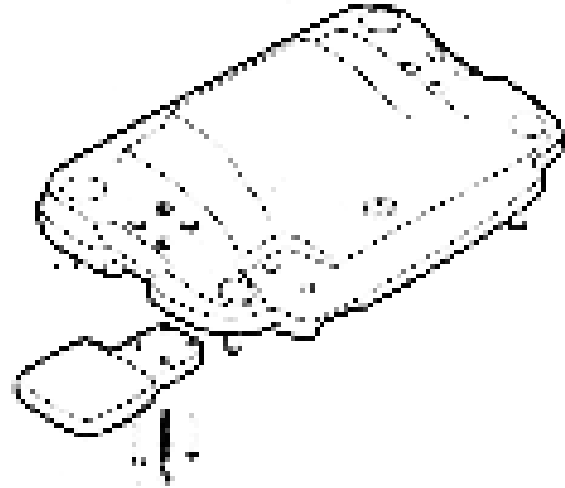



## TABLE OF COMPONENTS

Components	Stella A	Stella B	Stella C
<b>Stella Pack</b>	✓	✓	✓
Base (Tray)	✓	✓	✓
Lid	✓	✓	✓
Drainage Hose	✓	✓	✓
Instructions for Use	✓	✓	✓
Quick Guide Wall Chart	✓	✓	✓
Help Guide Wall Chart	✓	✓	✓
<b>Stella IQ Pack</b>	✓	✓	✓
Stella IQ	✓	✓	✓
Power Adaptor	✓	✓	✓
USB Cable	✓	✓	✓
<b>Stella Pulse Pack</b>		✓	✓
Stella Pulse		✓	✓
Stella Pulse Tube Set		✓	✓
Power Adaptor		✓	✓
<b>Stella Cradle Pack</b>	✓	✓	✓
Cradle	✓	✓	✓
Assembly Instructions	✓	✓	✓
<b>Stella Cradle Shelf Pack</b>		✓	✓
Cradle Shelf		✓	✓
Shelf Fixings		✓	✓
Assembly Instructions		✓	✓
<b>Stella System Toolbox</b>		✓	✓
Small Parts Tray and Lid	✓	✓	✓
Stella Lube	✓	✓	✓
Grommets (2)	✓	✓	✓
Drainage Outlet Cap		✓	✓
Stella Pump Hose Replacement Kit		✓	✓
Surrogate Lumen Kit		✓	✓
Dual Luer Lock Connector		✓	✓
Stella Jug	✓	✓	✓
Manual Emergency Kit* not available in Germany	✓	✓	✓

## SPECIFICATIONS AND STORAGE

**Stella System A:** 70cm x 6cm x 23-26cm (depends on cradle levelling leg length)

**Stella Systems B and C:** 82cm x 46cm x 23-26cm (depends on cradle levelling leg length)

**Lid:** 70cm x 40cm x 4cm

**Base:** 64cm x 39cm x 14cm

**Cradle (without Cradle Shelf):** Stella A: 65cm x 46 cm x 15-18cm (depends on cradle levelling leg length)

Stella B: 80cm x 46 cm x 15-18cm (depends on cradle levelling leg length)

**Drainage Hose:** 6cm protruding, 100cm (tubing) + 6cm (connector) long

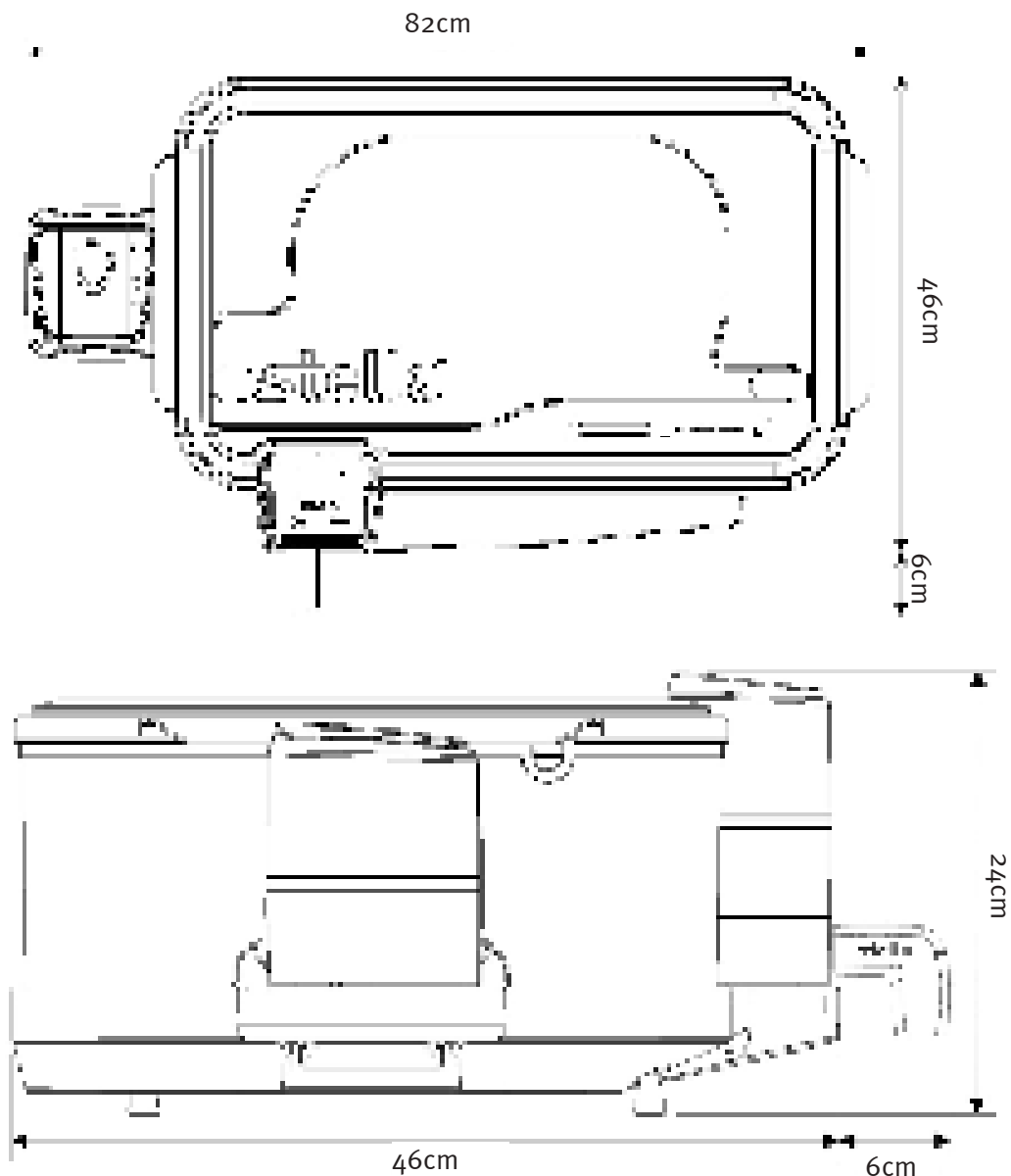

The Base and Lid can be easily stacked and transported. When empty the weight is 5.5kg.

The Drainage Outlet Cap can be used when transporting the Base to contain any small droplets of disinfectant left in the Base.

IQ and Pulse should be operated and charged in temperatures between 10-35°C with a maximum allowable humidity of 90%.

IQ and Pulse should be stored in temperatures between -10-40°C.

# SECTION THREE

## GETTING STARTED

## SECTION 3, GETTING STARTED

- Remove all components from their packaging. Ensure all components of the Stella System are clean and free of debris.
- Inspect Stella components. If missing or damaged, report to your local Stella Agent.
- Use the supplied power adaptors to charge IQ and Pulse for 12 - 16 hours before first use.
- Install the Stella Suite Software.

### INSTALLING THE STELLA SUITE SOFTWARE

Stella Suite is the software that allows the user to download important information or to update the firmware relating to IQ and Pulse, and events relating to the disinfection cycle.

*Windows is a supported operating System for Stella Suite. Apple is not supported.*

Stella Suite software is available via <https://tristel.com/stella-suite/>. Please download it using a PC or Laptop prior to using the Stella System, following the instructions on the screen.

If an update or additional components are purchased, please ensure you install the relevant firmware for your Stella package. Refer to your local Stella Agent if you are unsure.

### SETTING UP THE STELLA SYSTEM

Place Stella Cradle on the surface where the Stella System will be positioned.

Adjust the feet until the bubble in the circular vial level is centred.

Stella Cradle is now ready for you to position your Stella System.

For Stella B or C, select which side of the Cradle you want the shelf. Most installations have the cradle on the left-hand side, which is preferable, but the right-hand side is also an option.

Position the Stella Cradle Shelf under the cradle and insert the connector bolts up through the shelf to screw them into the connector nuts.

Using the two Allen Keys hold the connector nut in place with one key, then screw in the connector bolt on the other side with the second key. Repeat this until each of the x 4 connector bolts are in place and tightened.



*It is important to ensure that Stella is operated on a stable and level surface. Otherwise, the automatic sensor that triggers the cycle will not operate reliably.*

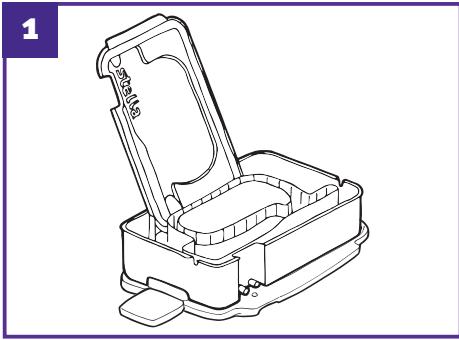

Once level, place the Base onto the Cradle. Stand the Lid in an upright position at the rear of the Base.

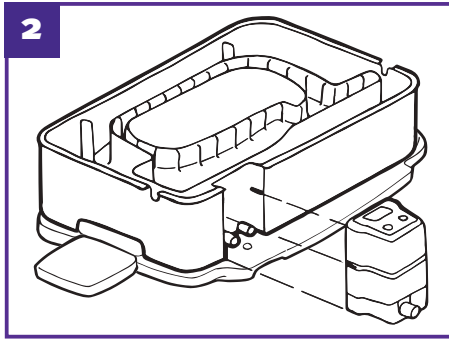

Apply a little amount of Lube lubricant onto the IQ drainage inlets. (See Section 5 Maintenance, Lubing IQ)

Firmly attach the IQ to the Base.

*Failure to ensure the correct connection may result in a leak.*

The drainage outlets from the Base slide into the drainage inlets in the IQ.



Firmly connect the Drainage Hose to IQ and ensure the end of the tube is directed into a sink or waste container. Ensure that the end of the Drainage Hose is in a downward position and not immersed in the waste solution, i.e. ensure there is an air gap.

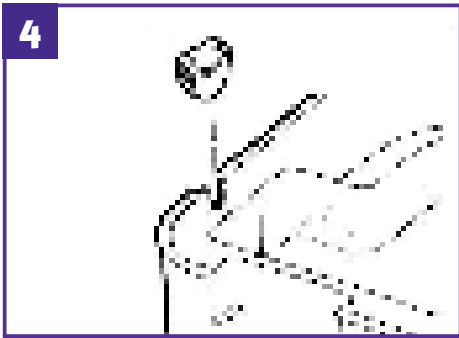

Apply the grommets into the tray cut-outs.

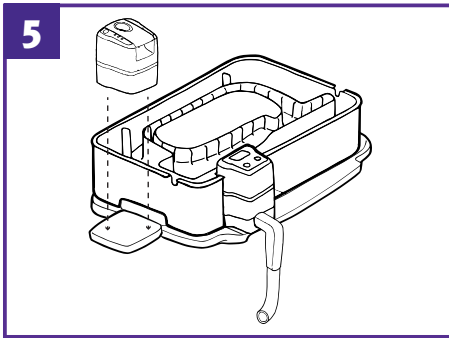

The next two steps relate to Stella B and C only. Place Pulse on the Cradle Shelf.



Remove the grommet nearest to Pulse. Attach the Tube Set to Pulse by matching the male and female connectors. Place the green tube mount provided firmly onto the Base cut-out.

Ensure that the disinfectant pick-up/filter is sitting in the inner compartment of the Base.

The Stella System is now ready to use.

# SECTION FOUR

## HOW TO USE

## SECTION 4, HOW TO USE

### STELLA SYSTEM A

- Ensure the medical device has been cleaned according to the hospital standard procedures before performing high-level disinfection with Stella System A. Tristel Clean for Stella, Tristel Pre-Clean Wipes or Tristel Clean are recommended. Please refer to the medical device manufacturer's care card or material compatibility approval list.
- Disinfect hands and wear appropriate Personal Protective Equipment (PPE) when handling disinfectants and medical devices.
- Do not attempt to move Stella whilst it is filled with solution.

#### Step 1

Push and hold the ON button on IQ until you hear a beep and follow the instructions shown on the screen. IQ performs a short self-check.

#### Step 2

When prompted by IQ, place a clean device into the device compartment. Position the device in a way that best fits the shape of the compartment, ensuring any connectors or non-immersible parts are placed outside of the tray via the designated cut-outs. If the device is completely submersible, seal the cut-outs with the grommets provided.

*Devices that do not fit correctly in the device compartment must not be used in the Stella System. Ensure that the Stella lid can be completely closed.*

#### Step 3

Any small re-usable parts from the device should be placed in the Small Parts Tray with the Lid closed and positioned into one of the two positions available within the device compartment, to the left or right of IQ.

#### Step 4

Prepare five litres of Tristel Fuse for Stella working solution in the Stella Jug in accordance with the user instructions.

#### Step 5

When prompted by IQ pour five litres of Tristel Fuse for Stella disinfectant into the device compartment.

*It is recommended to position the Jug on the outer wall of the Base, just right of IQ, and tilt the Jug slowly, supporting the base of the Jug with one hand. All five litres must be added. The disinfectant will overflow over the edges of the inner compartment into the overflow compartment of the Base. It will drain out immediately.*



*If Tristel Fuse for Stella is not added to Stella within 10 minutes, the cycle will be automatically aborted by IQ.*

#### Step 6

Allow up to 10 seconds for the liquid sensor to detect the Tristel Fuse for Stella working solution in the Base. The correct level of disinfectant automatically triggers the contact time countdown. An audible beep confirms the start of the five-minute disinfection cycle.

#### Step 7

Place the Lid onto the Base, ensuring it is closed tightly. Closing the Lid will displace more disinfectant solution into the overflow compartment. IQ displays the five-minute contact time countdown.



*Do not turn off IQ during the contact time as this will lead to ineffective disinfection and the disinfection cycle will be recorded as invalid, with no Validation Code.*

### Step 8

After the completed contact time, Stella drains the disinfectant automatically. The draining process may take up to one minute.

*Tristel Fuse for Stella does not require rinsing, based on clinical and toxicological studies.*

### Step 9

When the Base is empty, you will hear a beep indicating that the cycle is complete. Press the OK button to acknowledge that the cycle is complete. The disinfected device can now be removed for immediate use or to be placed in storage.

*Follow hospital procedures and manufacturer's instructions for device drying and storage.*

### Step 10

Press the OK button again to confirm the removal of the device, prompting IQ to display a Validation Code. This Validation Code should be noted in the Stella Quality Audit Trail Record Book or scanned by Tristel 3T for traceability.

*Failure to confirm the removal of the device will result in the IQ display backlight dimming after 5 mins.*

*After 10 minutes IQ will also shut down. When the unit is turned on again, the Validation Code can still be retrieved by pressing the OK button.*

A new cycle can be started by pressing the OK button again.

## SHUTDOWN PROCEDURE FOR STELLA SYSTEM A

Turn off IQ by pressing the OFF button. You will hear a beep indicating that IQ is switching off.

*If IQ is not turned off manually within 1 minute, the backlight will dim, If not attended within 5 minutes IQ will shut down. It is recommended to turn off IQ immediately after use to save the battery.*

After IQ has been switched off, it can be detached from the Base.

*With the drainage outlet cap fitted into place, the Base can be used as a transportation unit. Wipe the unit down with a soft, low, or non-linting wipe to remove any spills from the drain.*





## STELLA SYSTEM B

- Ensure the medical device has been cleaned according to the hospital standard procedures before performing high-level disinfection with Stella System B. Tristel Clean for Stella is recommended. Please refer to the medical device manufacturer's care card or material compatibility approval list.
- Disinfect hands and wear appropriate Personal Protective Equipment (PPE) when handling disinfectants and medical devices.
- Do not attempt to move Stella whilst it is filled with solution.

### Step 1

Push and hold the ON button on IQ until you hear a beep. Push and hold the ON button on Pulse until you hear a beep. IQ performs a short self-check. IQ automatically connects to Pulse and a Bluetooth sign confirms the connection. This will remain visible throughout the operation. Follow the instructions shown on the IQ screen.

### Step 2

When prompted by IQ, place a clean device into the device compartment. Position the device in a way that best fits the shape of the compartment, ensuring any connectors or non-immersible parts are placed outside of the tray via the designated cut-out. If the device is completely submersible, seal the right cut-out with the grommet provided.

*Devices that do not fit correctly in the device compartment must not be used in the Stella System. Ensure the Lid can be completely closed.*

Always refer to the manufacturer's instructions for immersion levels and guidance on how to place the devices into the Base.

### Step 3

If the device features a lumen, attach the Pulse Tube Set Luer Lock connector to the device's lumen port and ensure the tap is in the open position (if applicable).

Some devices have two fixed ports that cannot be removed and taken apart. These two ports will feed into the same working channel, therefore both port entries must be disinfected. To do this, use the Dual Luer Lock connector. Connect both connectors to the fixed instrument ports. Ensure both taps are in the open position.

If the device to be disinfected does not feature a lumen, connect the Surrogate Lumen to the Pulse Tube Set.

### Step 4

Any small re-usable parts from the device should be placed in the Small Parts Tray with the lid closed and positioned into one of the two positions available within the device compartment, to the left or right of IQ.

### Step 5

Prepare five litres of Tristel Fuse for Stella working solution in the Stella Jug in accordance with the user instructions.

### Step 6

When prompted by IQ pour five litres of Tristel Fuse for Stella working solution into the Device compartment.

*It is recommended to position the Jug on the outer wall of the Base, just right of IQ, and tilt the Jug slowly, supporting the base of the Jug with one hand. All five litres must be added. The disinfectant will overflow over the edges of the inner compartment into the overflow compartment of the Base. It will drain out immediately.*



*If Tristel Fuse for Stella is not added to Stella within 10 minutes, the cycle will be automatically aborted by IQ.*

### Step 7

Allow up to 10 seconds for the liquid sensor to detect the Tristel Fuse for Stella working solution in the Base. The correct level of disinfectant automatically triggers the contact time countdown. An audible beep confirms the start of the disinfection cycle.

### Step 8

Place the Lid onto the Base, ensuring it is closed tightly. Closing the Lid will displace more disinfectant solution into the overflow compartment. At the beginning, the Pulse pumps the disinfectant through the device channel for 1 minute. The system then rests until the five-minute contact time has passed. IQ displays the contact time remaining. At the end, Pulse pumps disinfectant solution through the device channel again.



*Do not turn off IQ during the contact time as this will lead to ineffective disinfection and the disinfection cycle will be recorded as invalid, with no validation code.*

### Step 9

After the completed contact time Stella drains the disinfectant automatically. The draining process may take up to one minute.

*Tristel Fuse for Stella does not require rinsing, based on clinical and toxicological studies.*

### Step 10

When the Base is empty, you will hear a beep indicating that the cycle is complete. Press the OK button to acknowledge that the cycle is complete. The disinfected device can now be removed for immediate use or to be placed in storage.

*Follow hospital procedures and manufacturer's instructions for device drying and storage.*

### Step 11

Press the OK button again to confirm the removal of the device, prompting IQ to display a Validation Code. This Validation Code should be noted in the Stella Quality Audit Trail Record Book or scanned by Tristel 3T for traceability.

*Failure to confirm the removal of the device will result in the IQ display backlight dimming after 5 mins, and Pulse will shut down. After 10 minutes IQ will also shut down. When the unit is turned on again, the Validation Code can still be retrieved by pressing the OK button.*

A new cycle can be started by pressing the OK button again.

## SHUTDOWN PROCEDURE STELLA SYSTEM B

Turn off IQ by pressing the OFF button. You will hear a beep indicating that IQ is switching off. When IQ is turned off, Pulse will switch off automatically.

*If IQ is not turned off manually within 1 minute the backlight will dim, if not attended with in 5 minutes the IQ and Pulse will shut down. It is recommended to turn off IQ immediately after use to save the battery.*

After IQ has been switched off, it can be detached from the Base.

*With the drainage outlet cap fitted into place, the Base can be used as a transportation unit. Wipe the unit down with a soft, low or non-linting wipe to remove any drops or spills from the drain.*

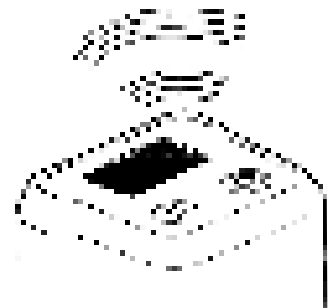

## STELLA SYSTEM C

- Ensure the medical device has been pre-cleaned according to the hospital standard procedures before performing cleaning and high-level disinfection with Stella System C. Tristel Clean for Stella is recommended. Please refer to the medical device manufacturer's care card or material compatibility approval list.
- Disinfect hands and wear appropriate Personal Protective Equipment (PPE) when handling disinfectants and medical devices.
- Do not attempt to move Stella whilst it is filled with solution.

### Step 1

Push and hold the ON button on IQ until you hear a beep. Push and hold the ON button on Pulse until you hear a beep. IQ performs a short self-check. IQ automatically connects to Pulse and a Bluetooth sign confirms the connection. This will remain visible throughout the operation. Follow the instructions shown on the IQ screen.

### Step 2

When prompted by IQ, place the manually pre-cleaned device into the Device compartment. Position the device in a way that best fits the shape of the compartment, ensuring any connectors or non-immersible parts are placed outside of the tray via the designated cut-out. If the device is completely submersible, seal the cut-out with the grommet provided.

*Devices that do not fit correctly in the Device compartment must not be used in the Stella System. Ensure the Stella lid can be completely closed.*

*Always refer to the manufacturer's instructions for immersion levels and guidance on how to place the devices into the Base.*

### Step 3

If the device to be cleaned/disinfected features a lumen, attach the Pulse Tube Set Luer Lock connector to the device's lumen port and ensure the tap is in the open position (if applicable).

Some devices have two fixed ports that cannot be removed and taken apart. These two ports will feed into the same working channel, therefore both port entries must be disinfected. To do this, use the Dual Luer Lock connector. Connect both connectors to the fixed instrument ports. Ensure both taps are in the open position.

If the device to be cleaned/disinfected does not feature a lumen, connect the Surrogate Lumen to the Pulse Tube Set.

### Step 4

Any small re-usable parts from the device should be placed in the Small Parts Tray with the lid closed and positioned into one of the two positions available within the Device compartment, to the left or right of IQ.

### Step 5

Prepare five litres of Tristel Clean for Stella working solution in the Stella Jug in accordance with the user instructions.

### Step 6

When prompted by IQ pour five litres of Tristel Clean for Stella working solution into the Base inner compartment.

*It is recommended to position the Jug on the outer wall of the Base, just right of the IQ, and tilt the Jug slowly, supporting the base of the Jug with one hand. All five litres must be added. The detergent solution will overflow over the edges of the inner compartment into the overflow compartment of the Base. It will drain out immediately.*

### Step 7

Place the lid onto the Base ensuring it is closed tightly. Closing the lid will displace more detergent solution into the Base overflow compartment. IQ displays the five-minute contact time countdown.

### Step 8

After the completed contact time Stella drains the detergent solution automatically. The draining process may take up to one minute.

*If a disinfection cycle does not follow within 15 minutes IQ will go to sleep to maintain battery life. If a disinfection cycle does not follow within 30 minutes the cycle will be automatically aborted by IQ, a new cleaning cycle must be started.*

If any visible residual soiling remains in the Stella Base following the cleaning cycle, this should be removed with a water-wetted, soft, low or non-linting wipe.

### Step 9

Prepare five litres of Tristel Fuse for Stella working solution in the Stella Jug in accordance with the user instructions.

### Step 10

When prompted by IQ pour five litres of Tristel Fuse for Stella working solution into the Base inner compartment.

*It is recommended to position the jug on the outer wall of the Base, just right of the IQ, and tilt the jug slowly, supporting the base of the jug with one hand. The disinfectant solution will overflow over the edges of the inner compartment into the overflow compartment of the Base. It will drain out immediately.*



*If Tristel Fuse for Stella is not added to Stella within 10 minutes, the cycle will be automatically aborted by IQ.*

### Step 11

Allow up to 10 seconds for the liquid sensor to detect the Tristel Fuse for Stella working solution in the Base. The correct level of disinfectant automatically triggers the contact time count down. An audible beep confirms the start of the five-minute disinfection cycle.

### Step 12

Place the Lid onto the Base ensuring it is closed tightly. Closing the Lid will displace more disinfectant solution into the overflow compartment. IQ displays the five-minute contact time countdown.



*Do not turn off IQ during the contact time as this will lead to ineffective disinfection and the disinfection cycle will be recorded as invalid, with no validation code.*

### Step 13

After the completed contact time Stella drains the disinfectant automatically. The draining process may take up to one minute.

*Tristel Fuse for Stella does not require rinsing, based on clinical and toxicological studies.*

### Step 14

When the Base is empty, you will hear a beep indicating that the cycle is complete. Press the OK button to acknowledge that the cycle is complete. The disinfected device can now be removed for immediate use or to be placed in storage.

*Follow hospital procedures and manufacturer's instructions for device drying and storage.*

### Step 15

Press the OK button again to confirm the removal of the device, prompting IQ to display a Validation Code. This Validation Code should be noted in the Stella Quality Audit Trail Record Book or scanned by Tristel 3T for traceability.

*Failure to confirm the removal of the device will result in the IQ display backlight dimming after 5 mins, and Pulse will shut down. After 10 minutes IQ will also shut down. When the unit is turned on again, the Validation Code can still be retrieved by pressing the OK button.*

A new cycle can immediately be started by pressing the OK button again.

## SHUTDOWN PROCEDURE STELLA SYSTEM C

Turn off IQ by pressing the OFF button. You will hear a beep indicating that IQ is switching off. When IQ is turned off, Pulse will switch off automatically.

*If IQ is not turned off manually within 1 minute the backlight will dim, if not attended within 5 minutes the IQ and Pulse will shut down. It is recommended to turn off IQ immediately after use to save the battery.*

After IQ has been switched off, it can be detached from the Base.

*With the drainage outlet cap fitted into place, the Base can be used as a transportation unit. Wipe the unit down with a soft, low or non-linting wipe to remove any drops or spills from the drain.*

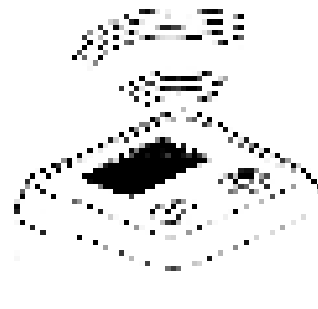

# SECTION FIVE

## MAINTENANCE

# SECTION 5, MAINTENANCE

## BATTERY MANAGEMENT

Always ensure IQ and Pulse are fully charged.

IQ will display the battery status for the full Stella System. If you have Stella System B or C, IQ will also display the battery status for Pulse. There are five indicators of charge, which will determine how many cycles can be performed.

		The battery is 76 - 100% full 60 - 80 cycles available
		The battery is 51 - 75% full 41 - 59 cycles available
		The battery is 26 - 50% full 21 - 40 cycles left
		The battery is 11 - 25% full 9 - 20 cycles left
		The battery is 0 - 10% full 0 - 8 cycles left

### Step 1

The power adaptor plug comes in two parts. Before use, fit the pins and the backing together ensuring they have clicked into place.

*To replace the power plug pins, press the release button, and remove.*

### Step 2

Disconnect IQ and Pulse from the Base and plug in the power adaptor via the power port on the back of the IQ and Pulse units.

*Only the supplied power adaptor should be used. The use of other adaptors may damage the equipment or cause malfunctions.*



*Do not charge IQ or Pulse whilst they are attached to the Base or near solution. Ingress of solution will cause damage or malfunctions to the equipment.*

### Step 3

Once plugged in, IQ will display the status of the charging.

## LUBING IQ PROCESS

During set up and every six months, a little amount of Lube should be applied to the IQ drainage inlets to ensure the IQ is connected securely onto the Base.

Wearing gloves, take a small amount of Lube and apply to the perimeter of each drainage inlet.

*Ensure the Lube is applied evenly. Do not apply Lube to the IQ drainage outlet, where the Drainage Hose is attached.*

## BLUETOOTH PAIRING PROCESS

The software on IQ and Pulse are already connected when supplied together. However, if either unit is replaced, they must be paired again.

### Step 1

Press the ON button to turn the Pulse.

### Step 2

On the IQ unit, press the ON button 3 times in quick succession so that Bluetooth Pulse Search is showing on the screen. The Bluetooth function will begin to search for available Pulse units.

### Step 3

When the Bluetooth link is established, serial numbers of any available Pulse units that are turned on, and unpaired, will display on the IQ screen.

### Step 4

If there is more than one Pulse unit listed, select the Pulse unit serial number you wish to pair with the IQ. This is done by pressing the ON button to move the blinking triangle on the IQ screen next to the correct Pulse unit serial number. Once the triangle shows up next to the correct Pulse unit, press and hold the IQ ON button for a minimum of four seconds until you hear a triple beep and the Bluetooth Pairing Complete graphic displays. Stella is now paired and ready for use.

## QR CODE VALIDATION

When a cycle has completed successfully, an alpha numeric Validation Code and QR code will be displayed on the IQ screen. This can be scanned by Tristel 3T, for digital traceability. To find out more about Tristel 3T, contact your local Stella Agent.

## BARCODE VALIDATION

If utilizing a scanning software package for audit trail, the Stella C variant can issue a Validation Barcode when a decontamination cycle has completed.

The barcode used is a 128 format. This feature operates with a 2D image scanner. A laser scanner cannot be used. To enable this feature, complete the following steps.

### Step 1

Connect the power adaptor to the mains power and IQ. Alternatively connect the USB to the PC and connect to IQ. (It is the connection to an electrical source (mains or PC) that enables the service screen selection where the change mode of operation is located on IQ).

### Step 2

Press IQ 'ON' button four times to enter the screen setting for the barcode option. There are two options available:

- Validation code without barcode
- Validation code with barcode

### Step 3

The option that is set is described in the top half of the graphic with a black background. To change the option, the ON key must be held for 3 seconds.

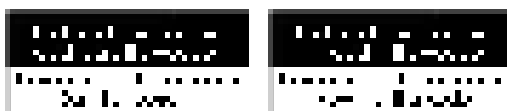



#### Step 4

When changing the barcode option, the user must press ON once again to confirm the change.



#### Step 5

Press the OFF key and remove the power adaptor or, if used, the USB cable respectively.

#### Step 6

Stella is now ready to use with the selected barcode option.

Example of validation barcode;



## DOWNLOADING

Each Stella cycle record is stored on IQ. This data should be frequently downloaded and stored as per hospital protocols. For a download to take place, Stella Suite Software must be installed on a PC or Laptop.

There are two options for downloading the data from IQ.

### VIA USB CABLE

#### Step 1

Open Stella Suite and connect the USB cable to your PC or Laptop and the IQ unit.

*IQ must be turned off. The connection port can be found on the back of the IQ, under a protective cover.*

#### Step 2

IQ will automatically detect the USB connection and the display will light up. *Do not press the ON button.*

#### Step 3

The USB Download symbol will appear on the IQ screen. On the Stella Suite toolbar, select the download option to begin transferring data.

#### Step 4

Once downloading is complete, disconnect the USB cable. IQ will automatically turn off.

*Remove the USB cable and reseal the protective cover on the IQ unit. Replace IQ back onto the Base before use.*

## VIA BLUETOOTH

The following instructions may vary depending on the Windows operating system being run.  
The following instructions are for Windows 10.

### Step 1

Enable Bluetooth communications on your PC or Laptop by going to Settings, Devices, + Add Bluetooth or other devices, and ensure Bluetooth is switched on.

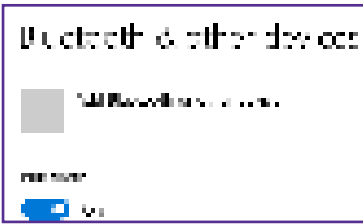

### Step 2

Press the IQ ON button twice in quick succession to display Bluetooth Download.

### Step 3

On the PC, select Add Bluetooth or other device, and choose Bluetooth. Bluetooth will now search for the IQ.

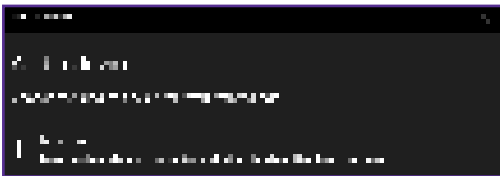

Select the IQ serial number to pair to. Select the IQ serial number to connect to.

If asked for a pairing code, use 1234.

Your device is now ready to go. Confirm Done.

### Step 4

Select More Bluetooth options in your PC related settings. In Bluetooth Settings select the COM Ports tab. Note the PORT number Outgoing for the IQ serial number being paired to.

### Step 5

Open Stella Suite. On the tool bar select File, Configure, then select the Bluetooth tab.

Tick the Use Bluetooth box.

Select the PORT number from Step 4.

Click OK. Bluetooth download is now enabled.

Select Download in Stella Suite to download.



### Step 6

Select Download in Stella Suite to download.

The "Progress" window shows the download status of the event log. When the download is complete, you can turn off the IQ by pressing the OFF button.

## REPLACING THE PUMP HOSE

Stella B Pump Hose should be changed every 1,000 disinfection cycles.

Stella C Pump Hose should be changed every 500 disinfection cycles.

IQ notifies “Replace Pump Hose” in the final 50 cycles.

The Pump Hose should be changed at any time between 50-0.

*The Stella Suite Report shows the number of cycles completed.*



When the Pump Hose has been replaced, ‘confirm replacement’ and a confirmation is displayed.



The Pump Hose replacement counter is reset.

Confirmation of the Pump Hose replacement is logged in the Stella Suite events which can be downloaded via the Stella Suite.

The equipment you will need for the Pump Hose replacement process:

- Pulse
- Pump Hose Replacement Set
- Flat Head Screwdriver located in the Toolbox

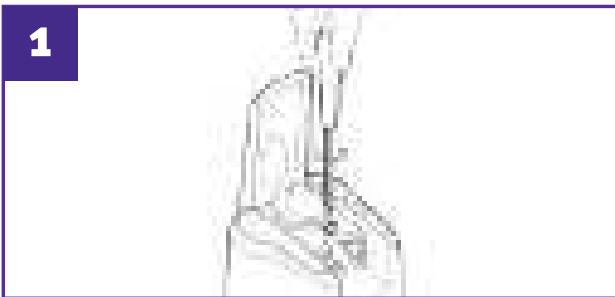

1 Ensure Pulse is turned off. Lift the green cover on Pulse. Using a flat head screwdriver, unscrew the clear window and remove from Pulse.

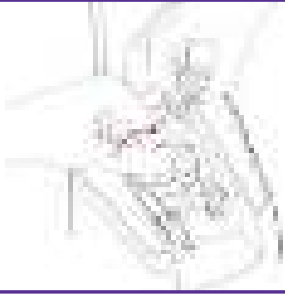

2 Remove the pump hose by lifting the pump hose connector on one side. Turn the green pump head clockwise to lift the curved hose, and then lift the pump hose connector on the second side.

**3**

Insert the new pump hose into Pulse. Place the left-hand pump hose connector in first. This is the smaller connector with the plastic point. The hose then curves around the green pump head which can be turned by hand. Check that the hose is pushed down at the rear of the green pump head. The right-hand pump hose connector is then locked into place.

*The pump hose connectors will not fit if they are not connected to the correct sides of Pulse.*

Each new Pulse unit comes with a fitted Pump Hose, and one spare Pump Hose Set. It is recommended that as soon as a hose is replaced, a spare part be ordered.

**4**

Replace the window, ensuring that the back ridge is pushed back correctly into Pulse and then fix the screw securely, taking care not to over tighten. *Pulse will not operate if the window is not replaced correctly.*

## REPLACING THE TUBE SET

The Stella B Tube Set should be replaced every 4,000 disinfection cycles.

The Stella C Tube Set should be replaced every 2,000 disinfection cycles.

*The Stella Suite Report shows the number of cycles completed.*

Remove the Tube Set from Pulse and attach the replacement Tube Set to Pulse by matching the male and female connectors. Place the green tube mount provided firmly on to the Base cut-out.

## CLEANING AND DISINFECTING STELLA

Tristel Clean for Stella and Tristel Fuse for Stella working solutions can be used for the cleaning and disinfection of the Stella System.

To clean the Stella System, dispense enough Tristel Clean for Stella working solution to saturate a non- or low-linting cloth, then squeeze to remove excess solution. Use the damp cloth to wipe the system until visibly clean, including IQ and Pulse.

To disinfect the Stella System, dispense enough Tristel Fuse for Stella working solution to saturate a non- or low-linting cloth, then squeeze to remove excess solution. Use the damp cloth to wipe the system, including IQ and Pulse. Ensure a contact time of five minutes. Dry with a soft cloth.

## DISPOSAL

The Base, Lid and Small Parts Tray can be disposed to plastic waste once decontaminated.

The IQ and Pulse units contain batteries and electronic components and must be disposed of in accordance with local regulations. The components should be decontaminated using chemical disinfectants prior to disposal, as recommended in **Cleaning and Disinfecting Stella**.

# SECTION SIX

## TROUBLESHOOTING AND FREQUENTLY ASKED QUESTIONS

# SECTION 6, TROUBLESHOOTING AND FREQUENTLY ASKED QUESTIONS

## GRAPHIC AND ALERTS

### Cycle Will Not Start

Five litres of Tristel Fuse for Stella working solution have been added to Stella, but the disinfection cycle does not start.

Ensure the Cradle is level, so the liquid sensor is able to detect the solution. Refer to Section 3, Getting Started for instructions on how to level the Cradle.



### X Stella xx/ X Stella IQ xx/ X Stella Pulse xx



In the event of equipment errors that cannot be resolved on site an X graphic will display.

Please make a note of the graphic details and contact your Stella Agent.

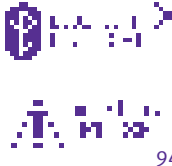
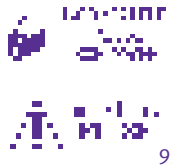

In the event of an operator error or an equipment error or an equipment error that may be resolved on site, a graphic will display with a number and may be followed by other graphics. Refer to the troubleshooting below and on the Help Guide Wall Chart. If the error cannot be resolved, or is not listed, contact your Stella Agent and advise them of the error code and graphics.

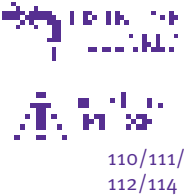
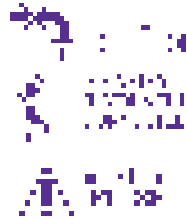
STELLA IQ SCREEN	WHAT HAPPENED?	WHAT SHOULD BE DONE?
	IQ has detected an obstruction and the ball valve will not close. There is no disinfectant in the Base.	<ul style="list-style-type: none"> <li>Remove IQ from the Base and inspect the IQ drainage outlets for blockages.                             <ul style="list-style-type: none"> <li>Remove any debris.</li> </ul> </li> <li>Refer to the Ball Valve Cleaning Procedure in the Service Manual.                             <ul style="list-style-type: none"> <li>Restart the cycle.</li> </ul> </li> <li>If the problem persists, contact your Stella Agent.</li> </ul>
	Pulse Bluetooth link has been lost. The disinfection cycle has not successfully completed and must be repeated.	<ul style="list-style-type: none"> <li>Turn off IQ and Pulse.</li> <li>Start the Bluetooth communication process again by first switching on IQ then Pulse.</li> <li>If this frequently occurs, contact your Stella Agent as the batteries may have aged and may require replacing.</li> </ul>
	Pulse Software is not compatible with IQ Software.	<ul style="list-style-type: none"> <li>Open Stella Suite and connect IQ via a USB cable to a computer or laptop.</li> <li>Go to the help menu and select Check for Software Updates.                             <ul style="list-style-type: none"> <li>When completed repeat the process with Pulse.</li> </ul> </li> <li>If Stella Suite is not installed, please see Section 3, Getting Started, INSTALLING THE STELLA SUITE SOFTWARE.</li> </ul>

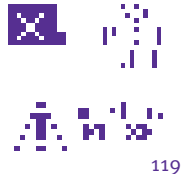
 <p>110/111/ 112/114</p>	<p>Pulse has detected a blockage which could be related to: the Pump Hose, Tube Set, Pulse Window not replaced correctly, a blocked device, or an device tap being closed.</p> <p>The disinfection cycle has not completed successfully. Disinfectant in the Base will be drained to waste.</p>	<ul style="list-style-type: none"> <li>• Check the device for blockages, check the device tap is not closed, and visually inspect the Tube Set connected to the device for blockages.</li> <li>• Open Pulse Window. Please see Section 5, Maintenance, Changing the Pump Hose.</li> <li>• Remove the Pump Hose and check that it is not pinched. If pinched, massage the tube to return to round shape. <ul style="list-style-type: none"> <li>• Replace the Pump Hose, replace Pulse Window and restart the cycle.</li> </ul> </li> </ul>
 <p>113</p>	<p>IQ is not detecting solution. The Pulse filter is either not submerged in the disinfectant or the left-hand Tube Set connection is not connected to the Pulse unit. If this occurs prior to the start of the disinfection cycle the user will be asked to Confirm Device Connected.</p>	<ul style="list-style-type: none"> <li>• First ensure that the filter is fully submerged in the solution, that the Tube Set is connected to the device and that the Tube Set Connectors are connected to the Pulse unit.</li> <li>• Confirm these checks have been completed by pressing the ON button.</li> <li>• After three failed attempts or after one minute has passed, the disinfection cycle will be aborted.</li> <li>• The disinfection cycle was not successful and must be repeated. <ul style="list-style-type: none"> <li>• If this error persists, contact your Stella Agent.</li> </ul> </li> </ul>
 <p>115/125</p>	<p>Stella has identified that the device has not been connected to Pulse or that it has become disconnected during the disinfection cycle.</p>	<ul style="list-style-type: none"> <li>• If this occurs prior to the start of the disinfection cycle, reconnect Pulse Luer Lock Connector to the device within a 30 second time frame and Confirm Device Connected by pressing the ON button. <ul style="list-style-type: none"> <li>• If the re-connection takes longer than 30 seconds, cannot be made, or is attempted during the disinfection cycle, the disinfectant solution will drain to waste.</li> </ul> </li> <li>• The disinfection cycle was not successful and must be repeated.</li> </ul>
 <p>119</p>	<p>Stella has not detected Tristel Fuse for Stella. The cycle has failed: the solution will be automatically drained from Stella.</p>	<ul style="list-style-type: none"> <li>• The disinfection cycle must be repeated with Tristel Fuse for Stella.</li> </ul>

## FAQs

### POWER

#### **Why is IQ or Pulse not powering up or operating intermittently?**

IQ will not start a cycle if there is not enough charge in the batteries to finish a full cycle. Place IQ and Pulse on charge for 12 - 16 hours. If IQ or Pulse still fails to power up, contact your Stella Agent.

#### **Why is my IQ and Pulse not charging correctly?**

Check that the green indicator light on the adapter is lit. If it is not lit, contact your Stella Agent.

*As IQ and Pulse batteries age, their capacity to store energy decreases. IQ and Pulse batteries have an in-use life of 5 years. After this time, they may need replacing.*

For further information refer to Electromagnetic Emission tables in the regulatory and warranty section of this manual.

### HARDWARE

#### **Why is water leaking from the Stella Base?**

Check IQ is attached firmly to the Base. Ensure that the Drainage Hose is attached and is watertight. Applying the Stella Lube (for instructions, see Maintenance section of this manual) will assist a firm fit to the Base.

#### **Why is water leaking from the IQ valve outlet?**

Excess liquid will exit the outlet when Stella is filled. When filling the Base inner compartment with five litres, a small amount of liquid will flow into the overflow compartment and out through the Drainage Hose at the start of a cycle.

If there is a continuous leak throughout the cycle, the valve may not have closed correctly.

Remove IQ from the Base.

**If the system is operating with IQ only**, press the ON button so that the valve inside IQ closes.

**If the system is operating with IQ and Pulse**, press the ON button on IQ and Pulse so that the valve inside IQ closes.

Make sure the black power cover is firmly sealed over the USB and power adaptor.

Flush by pouring a small jug of cold water into the right-hand IQ drainage inlet. Take care to direct the drainage outlet on the left-hand side towards the sink and avoid water contacting the top of the unit. Even though the valve is closed, water will still drain slowly from the drainage outlet.

Gently shake the IQ unit and then hold down the OFF button for 5 seconds. (In some cases, you may have found that the IQ wanted to start a disinfection cycle by itself as you were cleaning the sensor. If this happens, let it finish the cycle by itself as if it were connected to the Base).

Reattach the IQ and drainage hose to Base. Run a cycle to test if the issue has been cleared.

If the problem persists, contact your Stella Agent.

#### **Why are water leaks appearing from the electronics enclosure power cap?**

Discontinue use immediately and contact your Stella Agent.



## COMMUNICATION

### USB: Why is my Firmware not upgrading?



*IT services may need to complete the software installation. Check the USB cable is in good condition with no cable damage, broken or visible wires.*

Check plug connections are in good working order.

Check the Stella Suite installed on your computer is the latest version. The latest available version of Stella Suite software is available via the Stella product page on [tristel.com](http://tristel.com).

Refer to the Stella Suite Installation Guide for the correct installation process for your operating system.

The USB driver may have been installed in the incorrect location.

Go to the Start menu on your computer and select: Settings/ Control Panel/ System/ Hardware/ Device Manager.

Plug the USB cable into IQ first and then to your computer and observe where “USB Tristel” appears on your list. If it appears in the main list and not under Universal Serial Bus controllers, it needs to be shifted.

To shift select your device manager list and select ‘Update Driver’. Follow the wizard. In the wizard select ‘Search for the best drivers in these locations’ then browse to the following path: C:\Program Files\Stella\Stella Suite

The driver should now install in the correct location. When complete, unplug the USB from IQ.

### Bluetooth: Why is my download erratic or not possible?

Follow the “Stella Suite Bluetooth Installation User Guide” which can be found in the Help section of the Stella Suite. Stella Suite must be installed onto the computer, and the Bluetooth link configured according to the Bluetooth device instructions used on the computer.

### Why will IQ or Pulse not power up after a firmware update?

The firmware update may not have completed successfully. The update should be repeated. Open the Stella Suite, connect IQ to the PC via a USB Cable. Select ‘help’, then select the product you wish to update.

This should be completed for both IQ and Pulse units.



*During any firmware update, do not remove the USB cable until the update is 100% completed (denoted by two beeps).*



*Check USB cable or power adaptor is in good working condition.*

### Why is there an alarm going off after a firmware update?

The Firmware may not have installed correctly. Go to Stella Suite Help menu, select “Check for Stella IQ updates” and “Check for Stella Pulse updates”.

### I have downloaded my events, why can I not see them on the system anymore?

By default, the Stella Suite will only download events that took place since the last download. To view previous events, click on the EVENT FILTER Icon, choose the date range you would like to view events from then click OK. The events report will now be displayed.

## DAMAGE

If goods are damaged during delivery, it is the user’s responsibility to contact a Stella Agent.

If the equipment is dropped during use, the user should attempt to run a cycle through Stella to check it is operating correctly. If damage has occurred, contact a Stella Agent.

# SECTION SEVEN

## WARRANTY

## SECTION 7, WARRANTY

### WARRANTY FOR IQ AND PULSE

#### LIMITED WARRANTY

Tristel Solutions Limited (hereafter referred to as “the Company”) warrants that the Stella System, IQ, Pulse and associated parts and accessories (hereafter referred to as “the Product”) will conform to the Company’s written specifications and will be free from defects in material and workmanship under its designated, normal use and service.

Notwithstanding anything herein to the contrary, the warranty period for the Product supplied by the Company is twelve (12) months shown from the date of invoice.

Warranties shall be made invalid by the misuse of, or unauthorised tampering with, the Product.

The warranty does not cover, and the Company will have no warranty obligation whatsoever with respect to any damage to the Product caused by or associated with: (1) external causes, including without limitation, accident, vandalism, power failure or electrical power surges, (2) abuse, misuse or neglect of the Product by the customer or any other user or through use of unauthorised third party consumables and accessories, (3) usage not in accordance with the product Instructions For Use, (4) the customer’s failure to perform required preventive maintenance and care, or (5) servicing or repair not authorised by the Company.

#### LIMITATION OF REMEDY

The warranty obligation of the Company hereunder is limited to the repair or replacement (at its option) of the defective Product or any parts it deems defective. This will be the customer’s exclusive remedy for a covered defect.

In order to recover under the warranty, the customer must notify the Company or its representative in the country of installation of the defect prior to expiration of the warranty period and within thirty (30) days of discovery of the defect. The notification to the Company must include a description of the problem in reasonable detail and the full report downloadable from the IQ using the Stella Suite, showing all details starting seven (7) days before the defect was first noted. Upon receiving the Company’s official “return goods authorisation” (RGA), the customer must promptly return the defective part or Product to the Company (or the authorised representative) as indicated on the RGA, freight and insurance prepaid.

The Company will not be responsible for any damage during shipment.

#### WARRANTY DISCLAIMER

The Warranty above is the Company’s entire warranty obligation to the purchaser of the Product. It is in lieu of all other warranties of the Company, express or implied, including, without limitation, warranty of merchantability or fitness for a particular purpose, and the Company does not represent or warrant that any product will meet customer’s requirements. The Company’s responsibility for defects in a product is limited solely to repair and replacement as set forth in this warranty statement.

To the extent permitted by law, the Company shall not, under any circumstances, be liable to the customer for consequential, incidental, indirect or special damages or losses, including without limitation, damages arising out of or in connection with any malfunctions, delays, loss of profit, interruption of service, or loss of business or anticipatory profits, even if the Company has been apprised of the likelihood of such damages occurring.

This Warranty gives the customer specific legal rights, and customers may also have other rights which vary from jurisdiction to jurisdiction.

In no event shall the Company’s liability exceed the original purchase price of the covered Product. No representative or agent of the Company has the authority to bind the Company to any other representation or warranty with respect to the Products, and the customer accepts the Products subject to all of the terms above.

# SECTION EIGHT

## COMPLIANCE

## SECTION 8, COMPLIANCE

### TECHNICAL SPECIFICATIONS

TECHNICAL SPECIFICATIONS	
<b>Power adaptor</b>	FRIWO Model No. FW 7660M/12 GPP10-M (1950082)
AC mains	100~240Vac, 50/60Hz, 205~110mA, Interchangeable mains plugs
DC Output	12V ±2%, 800mA, 2.5mm DC Jack, (+) centre
Isolation Protection	Class II - AC mains and DC output are electrical safety isolated
Working Temperature	0°C ... +40°C
Storage Temperature	-20°C ... +70°C
Humidity	5% to 95%
Ingress Protection	IP40
Atmosphere Pressure	70-106kPa
Maximum Altitude	2.6km above sea level
Weight	160gm
Low Voltage Directive Safety Standard	IEC/EN 60601-1 ED, IEC60601-1, ES60601-1
EMC Directive	AS/NZS 3112, VDE EN50075, EN60950-1, UL1310
Cable Length	EN 60601-1-2, IEC EN 61326-1
<b>Stella IQ</b>	
Input Voltage	12 Vdc 200mA
Ingress Protection	IP64 with power cover closed. Dust tight, protected from water splash
Pollution Degree	Assessed to pollution degree 3. Conductive pollution is to be expected
Humidity	10% to 90%
Weight	840gm
Working Temperature	10°C ~ 35°C
Transport Temperature	-20°C to +50°C
Storage Temperature	-10°C to +40°C
Charge Temperature	10°C ~ 35°C
Low Voltage Directive	IEC/EN 61010-1, 61010-2-040 Part 2 – Washer Disinfectors
EMC Directive	IEC EN 61326-1
Battery Pack	Part No. 210AAHCB4BMLQM, 4.8V NiMH, 2000mAh, 117gm
Battery Standard Charge	200mA (0.1C) 16hrs, 6Vmax
Battery Service Life	IEC Cycles test ~500
<b>Stella Pulse</b>	
Input Voltage	12Vdc, 750mA
Ingress Protection	IP64 With Power cover closed. Dust tight, protected from water splash
Pollution Degree	Assessed to pollution degree 3. Conductive pollution is to be expected
Humidity	5% to 90%

Weight	1560gm
Working temperature	10°C ~ 35°C
Storage temperature	-10°C to +40°C
Transport temperature	-20°C to +50°C
Charge temperature	10°C ~ 35°C
Low Voltage Directive	IEC/EN 61010-1, 61010-2-040 Part 2 – Washer Disinfectors
EMC Directive	IEC EN 61326-1
Battery Pack	Part No. 450LAH10YQM, 12V NiMH, 4500mAh, 622gm.
Battery standard charge	450mA (0.1C) 16hrs, 15Vmax
Battery Service Life	IEC Cycles test >250
Base capacity	5 Litres
Weight	5.9kg when empty

## REGULATORY COMPLIANCE

### REGULATORY

The Stella System is CE marked as a Class IIb medical device as per the Medical Device Directive 93/42/EEC and the 2007/47/ EC amendments thereto, for washer – disinfectors intended for disinfecting invasive devices and Low Voltage Directive (LVD) 2014/35/EU.

	Council Directive (EU) 2017/745 of 5 April 2017 concerning medical devices
Directive (LVD) 2014/35/EU	Low Voltage Directive (LVD) 2014/35/EU enforced 23 April 2016
Directive (EMC) 2014/30/EU	Electromagnetic Compatibility (EMC) 2014/30/EU enforced 20 April 2016
BS EN ISO 13485:2016	Medical Devices - Qualitative management systems. Requirements for regulatory purposes
BS EN 60601-1:2006 +A12:2014	Medical electrical equipment. General requirements for basic safety and essential performance – (Relating to Power Adaptor)
AS 61010.1:2003(R2016) BS EN 61010-1:2010+A1:2019 IEC 61010-1 3.1: 2017	Medical Electrical Equipment. Part 1: Safety requirements for electrical equipment for measurement, control, and laboratory use. General requirements
BS EN 61010-2-040:2015 Part 2-040	Safety requirements for electrical equipment for measurement, control and Laboratory use – Particular requirements for sterilisers and washer disinfectors used to treat medical devices
BS EN 61326-1:2013 IEC 61326-1:2012	Electrical equipment for measurement, control and laboratory use. EMC requirements. General requirements
BS EN 62366-1:2015	Medical devices. Application of usability engineering to medical devices
BS EN 62304:2006+A1:2015	Medical device software. Software life-cycle processes
BS EN 61000-3-2:2014 IEC 61000-3-2:2014 Ed4.0	Electromagnetic compatibility (EMC) - limits for harmonic current emissions
BS EN 61000-3-3:2013 IEC 61000-3-3:2013 Ed 3.0	Electromagnetic compatibility (EMC) - limitation of voltage changes, voltage fluctuations and flicker in public low voltage supply systems
AS/NZS CISPR 11:2011 BS EN 55011:2009 CISPR11: 2009 + A1: 2010	Industrial, scientific and medical equipment. Radio-frequency disturbance characteristics. Limits and methods of measurement.
AS/NZS 61000-4-2:2013 BS EN 61000-4-2:2009 IEC 61000-4-2:2008	Electromagnetic compatibility (EMC) - testing and measurement techniques – electrostatic discharge immunity test
AS/NZS 61000-4-3:2013 BS EN 61000-4-3:2006 +A1: 2010 IEC 61000-4-3:2006 +A1:2007+A2:2010	Electromagnetic compatibility (EMC) - testing and measurement techniques – radiated, radiofrequency, electromagnetic field immunity test

# ELECTROMAGNETIC EMISSIONS AND IMMUNITY IEC 61326-1:2013

## STELLA

For electromagnetic emissions the Stella System has been tested for compliance to IEC 61326-1, CISPR11 Group 1, Class B. Testing has been performed using the following parts with Stella System.

ITEM DESCRIPTION	LENGTH	MANUFACTURER	PART NUMBER
USB Cable Type A to B	1m	Dynamix	C-U2AB-1
GPP10 Medial Power Plug Pack	1.8m DC lead	FRIWO	1950067

## WARNINGS

Use of accessories and cables other than those specified, with the exception of the power pack and cables sold by the manufacturer of the Stella System as replacement, may result in increased emissions or decreased immunity of the Stella System.

## ADJACENT EQUIPMENT

The Stella System should not be used adjacent to, or stacked with, other equipment. If adjacent or stacked use is necessary, the Stella System should be observed to verify normal operation in the configuration in which it will be used.

## OPERATION IN WET AREAS

Keep IQ and Pulse clear from wet areas when they are placed on charge or connected to a computer terminal using a USB cable. Do not attempt to use the Stella System for disinfection purposes while charging or downloading. In the case of long-term storage, remove IQ and Pulse from the Base and keep it clear from wet areas.

## CLOSE POWER CAP

Remove all cables from IQ and Pulse and ensure the rear power caps are closed firmly while IQ or Pulse are in use during cleaning and disinfection cycles.

Declaration for compliance: The Stella System complies with all IEC 61326-1 Test Levels of this collateral standard for power frequency magnetic field immunity requirement.

# IEC 61326-1:2013 TABLE 1 – BASIC IMMUNITY

Declaration for compliance: The Stella System complies with all IEC 61326-1 Test Levels of this collateral standard for power frequency magnetic field immunity requirement.

MANUFACTURER'S DECLARATION – ELECTROMAGNETIC IMMUNITY				
Immunity test requirements for equipment intended to be used in a basic electromagnetic environment.				
Port	Phenomenon	Basic Standard	Test value	Performance Criterion
Enclosure	Electrostatic Discharge (ESD)	IEC 61000-4-2	4 kV contact discharge 8 kV air discharge	B B
	Electromagnetic Field	IEC 61000-4-3	3 V/m (80 MHz to 1 GHz) 3 V/m (1.4 GHz to 2 GHz) 1 V/m (2.0 GHz to 2.7 GHz)	A A A
	Power frequency magnetic field	IEC 61000-4-8	3 A/m (50 Hz, 60 Hz)	A
AC Power (Including protective earth)	Voltage dip	IEC 61000-4-11	0% during half cycle 0% during 1 cycle 70% during 25/30 cycles	B B C
	Short interruptions	IEC 61000-4-11	0% during 250/300 cycles	C
	Burst	IEC 61000-4-4	1 kV (5/50 ns, 5 kHz)	B
	Surge	IEC 61000-4-5	0.5 kV/1 kV	B
	Conducted RF	IEC 61000-4-6	3 V (150 kHz to 80 MHz)	A
DC power (including protective earth)	Burst	IEC 61000-4-4	1 kV (5/50 ns, 5 kHz)	B
	Surge	IEC 61000-4-5	0.5 kV/1 kV	B
	Conducted RF	IEC 61000-4-6	3 V (150 kHz to 80 MHz)	A
I/O signal/ control (including functional earth)	Burst	IEC 61000-4-4	1 kV (5/50 ns, 5 kHz)	B
	Surge	IEC 61000-4-5	0.5 kV/1 kV	B
	Conducted RF	IEC 61000-4-6	3 V (150 kHz to 80 MHz)	A
<p>Mains power quality should be that of a typical domestic or hospital environment. If disturbance occurs, it may be necessary to position the Stella System further from sources of power frequency magnetic fields or install magnetic shielding.</p>				



# IEC 61326-1:2013 TABLE 2 – EMISSIONS

Declaration for compliance: Stella System complies with CISPR11, group 1, Class B, IEC 61000-3-2 and IEC 61000-3-3.

MANUFACTURER'S DECLARATION – ELECTROMAGNETIC EMISSIONS		
<p>The Stella System is intended for use in the electromagnetic environment specified below. The end-user of the Stella System should ensure that it is used in such an environment.</p>		
Emissions test	Compliance standard	Test level
RF emissions energy level	CISPR 11	Group 1 - RF energy only for its internal function
RF emissions environment category	CISPR 11	Class B - All establishments including domestic
AC power - Conducted emissions	CISPR 11	150 kHz - 30 MHz
Enclosure - Radiated emissions	CISPR 11	Group 1 equipment - 30 MHz to 1 GHz (OATS)
AC power - Harmonic emissions	IEC 61000-3-2	Measurement up to 40th harmonic
AC power - Flicker	IEC 61000-3-3	Traceable results only - Complies
<p>Electromagnetic environment – guidance</p>		
<p>Group 1 - The Stella System uses RF energy only for its internal function. Therefore, its RF emissions are very low and are not likely to cause any interference in nearby electronic equipment.</p>		
<p>Class B - The Stella System is suitable for use in all establishments, including domestic establishments and those directly connected to the public low-voltage power supply network that supplies buildings used for domestic purposes</p>		

## IEC 60601-1-2:2007 (5.2.2.1) TABLE 3

Declaration of compliance: Stella System which is non-life supporting device that meets IEC 60601 Test Levels of this collateral standard for the radiated and conducted immunity tests.

GUIDANCE AND MANUFACTURER'S DECLARATION – ELECTROMAGNETIC IMMUNITY			
<p>The Stella System is intended for use in the electromagnetic environment specified below. The end-user of the Stella System should ensure that it is used in such an environment.</p>			
Immunity test	IEC 60601 Test level	Compliance Level	Electromagnetic environment – guidance
<p>Conducted RF IEC 61000-4-6</p> <p>Radiate RF IEC 61000-4-3</p>	<p>3 Vrms 150 kHz to 80 Mhz</p> <p>3 V/m 80 MHz to 2.5 GHz</p>	<p>3 Vrms</p> <p>3 V/m</p>	<p>Portable and mobile RF communications equipment should be used no closer to any part of the Stella IQ, including cables, than recommended separation distance calculated from the equation applicable to the frequency of the transmitter.</p> <p>Recommended separation distance:</p> $d = 1,2 \sqrt{P}$ <p><math>d = 1,2 \sqrt{P}</math> 80 MHz to 800 MHz</p> <p><math>d = 2,3 \sqrt{P}</math> 800 MHz to 2.5 GHz</p> <p>where p is the maximum output power rating of the transmitter in watts (W) according to the transmitter manufacturer and d is the recommended separation distance in meters (m).</p> <p>Field strengths from fixed RF transmitters, as determined by an electromagnetic site survey <sup>A</sup>, should be less than the compliance level in each frequency range <sup>B</sup>.</p> <p>Interference may occur in the vicinity of equipment marked with the following symbol:</p> 
<ul style="list-style-type: none"> <li>• At 80 MHz and 800 MHz, the higher frequency applies.</li> <li>• These guidelines may not apply in all situations. Electromagnetic propagation is affected by absorption and reflection from structures and people.</li> </ul>			
<p><sup>A</sup> Field strengths from fixed transmitters, such as base stations for radio (cellular/cordless) telephones and land mobile radios, amateur radio, AM and FM radio broadcast cannot be predicted theoretically with accuracy. To assess the electromagnetic environment due to fixed RF transmitters, an electromagnetic site survey should be considered. If the measured field strength in the location in which the Stella System is used exceeds the applicable RF compliance level above, the Stella System should be observed to verify normal operation. If abnormal performance is observed, additional measures may be necessary, such as re-orientation or relocation of the Stella System.</p> <p><sup>B</sup> Over the frequency range 150 kHz to 80 MHz, field strengths should be less than 3 V/m.</p>			

## IEC 60601-1-2:2007 (5.2.2.1) TABLE 4

Recommended separation distances between portable and mobile RF communications equipment and the Stella System.









The Stella System is intended for use in an electromagnetic environment in which radiated RF disturbances are controlled. The end user of the Stella System can help prevent electromagnetic interference by maintaining a minimum distance between the portable and mobile RF communications equipment (transmitters) and the Stella System as recommended below, according to the maximum output power of the communications equipment.









Rated maximum output power of transmitter Watts (W)	Separation distance to frequency of transmitter – meters (m)		
	150 kHz to 80 MHz $d = 1.2 \sqrt{P}$		150 kHz to 80 MHz $d = 1.2 \sqrt{P}$
0.01	0.12	0.12	0.23
0.1	0.38	0.38	0.73
1	1.2	1.2	2.3
10	3.8	3.8	7.3
100	12	12	23

For transmitters rated at a maximum output power not listed above, the recommended separation distances in meters (m) can be estimated using the equation applicable to the frequency of the transmitter, where p is the maximum output power rating of the transmitter in watts (W) according to the transmitter manufacturer.

- At 80 MHz and 800 MHz, the higher frequency applies.
- These guidelines may not apply in all situations. Electromagnetic propagation is affected by absorption and reflection from structures and people.

# GLOSSARY OF THE GRAPHICAL SYMBOLS USED ON THE STELLA SYSTEM

OBSERVE ALL SYMBOLS – SYMBOLS ARE FOR YOUR SAFETY AND ENVIRONMENTAL PROTECTION	
	<p><b>Read instructions before use</b></p> <p>This manual contains information for the safe use and handling of the Stella system and power supply. It explains the installation and the mains adaptor power supply for charging the Stella units.</p>
	<p><b>IQ Graphic indicating user error or equipment error that may be resolved on site</b></p> <ul style="list-style-type: none"> <li>In the event of an operator error or an equipment error that may be resolved on site, this symbol will be displayed</li> <li>Note whether the system is for Stella, Stella IQ or Stella with Pulse and the number following <ul style="list-style-type: none"> <li>Note if any other graphics are shown</li> <li>Refer to the troubleshooting guide or Help Guide Wall Chart</li> </ul> </li> <li>If the error cannot be resolved, or is not listed, contact your Stella Agent and advise them of the error code details and graphics</li> </ul>
	<p><b>Prevent shock-hazard</b></p> <ul style="list-style-type: none"> <li>Always read the instruction manual first before using the power supply <ul style="list-style-type: none"> <li>Risk of electric shock - Use approved Power Adaptor only</li> </ul> </li> <li>While charging place Stella units and power adaptor in a dry area <ul style="list-style-type: none"> <li>Do not use power adaptor in wet areas</li> </ul> </li> <li>Never use a power adaptor with damaged housing or cable <ul style="list-style-type: none"> <li>Never modify the power adaptor or opens its housing</li> <li>Connect the power adaptor to a regular power outlet</li> <li>Protect connectors from moisture and damp areas</li> </ul> </li> </ul>
	<p><b>Prevent property damage</b></p> <ul style="list-style-type: none"> <li>Never carry the power adaptor by its electrical cable or pull at the cable</li> <li>To remove the adaptor from the power outlet always pull on the plug, never the cable <ul style="list-style-type: none"> <li>The DC power cable must be installed safely to avoid tripping over <ul style="list-style-type: none"> <li>Disconnect the power supply during thunderstorms</li> </ul> </li> </ul> </li> <li>Only use original spare parts or accessories supplied with the power adaptor <ul style="list-style-type: none"> <li>Keep power covers closed when Stella units are in use</li> </ul> </li> </ul>
	<p><b>Personnel protection</b></p> <ul style="list-style-type: none"> <li>Wear protective clothing and protective eye wear during use <ul style="list-style-type: none"> <li>Do not place Stella units on charge in wet areas</li> <li>Keep working area and walkways clear of obstacles</li> </ul> </li> <li>Ensure appropriate safety precautions are observed during use</li> <li>Ensure adequate lighting is provided for the Stella system working area <ul style="list-style-type: none"> <li>Identify areas for potential leakage and rectify before use</li> <li>In the event of spillage clean and dry the area immediately</li> </ul> </li> </ul>
	<p><b>Operating Temperature</b></p> <p>Operation within 10°C to 35°C with a maximum allowable humidity of 90% (within the prescribed temperature range). Store and transport within the temperature range of -10°C to +40°C.</p>
	<p><b>For indoor use only</b></p> <p>Use Stella system in designated area for decontamination of medical devices.</p>
	<p><b>CE Mark</b></p> <p>The Stella Devices conform to the European Regulation (EU) 2017/745.</p>
	<p><b>FCC Mark</b></p> <p>The Stella system complies to the Federal Communications Commission Regulation FCC 47 CFR Part 15, Subpart B (Unintentional Radiators).</p>

<b>IP64</b>	<b>Ingress Protection</b> Protected against dust ingress and water spray from all directions with power covers closed. Limited ingress may occur.
	<b>Bluetooth enabled</b>
	<b>USB enabled</b>
	<b>Disposal</b> Recycle in accordance with the WEEE Directive. Under the European Directive 2012/19/EU this electronic device must not be disposed of to normal waste. Dispose of the Stella system, power adaptor and batteries via the designated take-back system. Contact your local supplier.
	<b>Restriction of Hazardous Substances - RoHS 3</b> Under the European Directive 2015/863 this electronic device complies with the maximum levels for restricted substances.
	<b>Material can be recycled</b>
<b>SN</b>	<b>Serial Number</b>
	<b>Lot Number</b>
	<b>Date of manufacture</b>
	<b>Fragile. Handle with care</b>
	<b>Do not stack pallets</b>

## MANUFACTURER

Tristel Solutions Limited  
Lynx Business Park, Fordham Road, Snailwell,  
Cambridgeshire, CB8 7NY, United Kingdom  
T +44 (0)1638 721 500 - F +44 (0)1638 721 911  
E mail@tristel.com - W www.tristel.com

**CE** The Stella system is CE marked as a Class IIb medical device as per the Medical Device Directive MDD 93/42/EEC and the 2007/47/ EC amendments thereto.  
**2797**

**EC REP** Tristel NV, Smallandlaan 14 B, 2660 Antwerp, Belgium

STL/019/17 - 26/MAY/2022  
Copyright © 2022 Tristel Solutions Limited.  
All rights reserved.

For Tristel patent information please visit:  
<http://www.our-patents.info/tristel>

No part of this publication may be reproduced or transmitted, in any form or by any means, electronic, mechanical, photocopying, recording or otherwise, or stored in a retrieval system of any nature without the written permission of Tristel Solutions Limited.

# SECTION NINE

## STELLA AGENTS

## SECTION 9, STELLA AGENTS

### AUSTRALASIA

#### NEW ZEALAND

Tristel New Zealand Limited  
23 Birch Avenue  
Judea, Tauranga  
New Zealand  
**T** +64 7 577 1560  
**E** mail-nz@tristel.com

#### AUSTRALIA

Tristel Pty  
40/328 Reserve Road  
Cheltenham, VIC 3192  
Australia  
**T** +1300 680 898  
**E** mail-au@tristel.com

### EUROPE

#### UNITED KINGDOM & REST OF THE WORLD

Tristel Solutions Limited  
Lynx Business Park  
Fordham Road, Snailwell  
Cambridgeshire  
CB8 7NY  
United Kingdom  
**T** +44 (0)1638 721 500  
**E** mail@tristel.com

#### FRANCE

Tristel SaS,  
130, Blvd de la Liberté  
59000 Lille  
France  
**T** +33 (0) 3 66 88 01 84  
**E** france@tristel.com

#### BELGIUM

Tristel NV  
Smallandlaan 14B  
2660 Antwerpen  
Belgium  
**T** +32 (0)3 889 26 40  
**E** belgium@tristel.com

#### THE NETHERLANDS

Tristel B.V.  
Binderij 7 R, 1185 Amstelveen  
The Netherlands  
**T** 020 808 51 34  
**E** nederland@tristel.com

#### GERMANY & AUSTRIA

Tristel GmbH  
Karl-Marx-Allee 90A  
10243 Berlin  
Germany  
**T** +49 (0)30 5484 4226  
**E** vertrieb@tristel.de

#### SWITZERLAND

ANKLIN AG  
Bodenmattstrasse 34  
4153 Reinach  
Switzerland  
**T** +41 61 717 55 55  
**E** info@anklin.ch

#### ICELAND

Icepharma  
Lyngháls 13  
110 Reykjavík  
Iceland  
**T** +354 540 4324  
**E** soley@icepharma.is

#### ITALY

Tristel Italia S.r.l.  
Via E. Collamarini  
14 40138 Bologna  
Italy  
**T** +39 051 0014912  
**E** www.tristel.it

#### PORTUGAL

Teprel – Equipamentos  
Médicos, S.A.  
Adress: Rua D. Marcos da Cruz,  
1997 – 1º Poente  
4455-482 Perafita  
Portugal  
**T** +351 22 999 9880  
**E** info@teprel.com

#### REPUBLIC OF IRELAND

Brennan & Company  
61 Birch Avenue  
Stillorgan Industrial Park  
Stillorgan, Co. Dublin  
Republic of Ireland  
**T** +353 (1) 295 2501  
**E** enquiries@brennanco.ie

#### DENMARK

ViCare Medical A/S  
Birkerød Kongevej 150B  
3460 Birkerød  
Denmark  
**T** +45 45 82 3366  
**E** info@vingmed.dk

#### FINLAND

Otoplug Oy  
Osuusmyllynkatu 7  
33700 Tampere  
Finland  
**T** +358 40 5789 330  
**E** otoplug@otoplug.fi

#### NORWAY

Vingmed AS  
Solbråveien 13  
1383 ASKER  
Norway  
**T** +47 67 58 06 80  
**E** info@vingmed-as.no

#### SWEDEN

Vingmed AB  
Datavägen 9A SE-175 43  
Järfälla  
Sweden  
**T** 08-583 593 00  
**E** info@vingmed.se

#### SLOVENIA

Medip d.o.o.  
Taborska cesta 4  
1290 Grosuplje  
Slovenia  
**T** +386 3177 3989  
**E** info@medip.si

#### SPAIN

Vesismin S.L.  
C/ Llucà 28, 5º planta  
08028-Barcelona  
Spain  
**T** +34 934 09 53 01  
**E** vesismín@vesismín.com

## EUROPE

### TURKEY

Yefe Dis Ticaret Ltd. Sti.  
Yesillik Cad. Selgecen Is Merkezi  
No:228-230 / 434 35380  
Karabaglar, Izmir  
Turkey  
**T** +90 232 264 19 23  
**E** info@yetaltd.com

### MALTA

Associated Equipment  
Lourdes Square  
Rihan Avenue  
San Gwann, SGN2010  
Malta  
**T** (+356) 21384347  
**E** purchasing@associated-  
equipment.com

## ASIA AND MIDDLE EAST

### CHINA

Tristel Medical Equipment  
(Shanghai) Ltd  
Room 203, 277 Danshui Road  
Huangpu District  
Shanghai 200025  
China  
**T** +86 (21)8016 2555  
**E** 888@tristel.com

### HONG KONG & MACAU (SAR)

Tristel Asia Limited  
21st Floor, Union Park Tower  
168 Electric Road  
Fortress Hill  
Hong Kong  
**T** +852 2895 6968  
**E** customerservicehk@tristel.com

### TAIWAN

Meta-Medic Co., Ltd.  
16/F - 1,  
No. 738 Zhongzheng Road  
Zhonghe District  
New Taipei City, Taiwan  
**T** +886 2 2369 8172  
**E** product@mediunion.com.tw

### ISRAEL

Sachar Medical Technologies  
20 Zvi Berkman St.  
Petach Tiquwa  
4927976  
Israel  
**T** + 972(7)75513925  
**E** sachar.medtech@gmail.com

### MALAYSIA

Tristel Malaysia Sdn.  
Bhd, A-25-3A Pinnacle PJ  
Lorong Utara C  
46200 Petaling Jaya  
Selangor Darul Ehsan  
Malaysia  
**T** +603 79317791  
**E** tristemalaysia@tristel.com

### SINGAPORE

EO Medical Pte. Ltd.  
29 Media Circle  
#04-23  
Singapore 138565  
**T** +65 6100 5060  
**E** orders@eo.com.sg

### PAKISTAN

Uniprom Healthcare  
L-151, 2nd Floor  
Sehba Akhter Road Block 13-G  
Gulshan-e-Iqbal  
Karachi  
Pakistan  
**T** +92 (41) 871 3751  
**E** info@unipromhealthcare.com

### SAUDI ARABIA

Fal Care Trading Est.  
P.O.Box: 48520  
Jeddah 21414  
Saudi Arabia  
**E** info@cayane.net

### UNITED ARAB EMIRATES, BAHRAIN, KUWAIT, QATAR, OMAN, JORDAN & LEBANON

Fal Care FZE  
Saif desk Q1-09-108/B PO Box  
514484 Sharja  
United Arab Emirates  
**E** info@falcare.com

## AFRICA

### SOUTH AFRICA

Be Safe Paramedical  
58 Promenade Road  
Muizenberg  
Cape Town  
7945  
South Africa  
**T** +27 (0) 21 788 4681  
**E** info@be-safe.co.za

For all other areas, please contact our headquarters in the United Kingdom.





A series of horizontal lines spanning the width of the page, designed for writing. The lines are evenly spaced and extend from the left margin to the right margin, leaving a narrow gap from the right edge of the page.





A series of horizontal lines for writing, spaced evenly down the page. The lines are thin and light gray, providing a guide for text entry.

**Tristel™**  
WE HAVE CHEMISTRY.